

0RQB-C5U12x Series

Isolated DC-DC Converter

The 0RQB-C5U12x is an isolated DC/DC converter that operates from a wide input range (18 VDC - 75 VDC) and can cover both 24 VDC and 48 VDC input range. This unit will provide up to 150 W of output power. This unit is designed to be highly efficient and low cost.

Features include remote on/off, over current protection, over voltage shut down, over temperature protection and under voltage lockout. This converter is provided in an industry standard 1/4 brick package.



RoHS
Compliant

Key Features & Benefits

- 18 VDC - 75 VDC Input
- 12 VDC / 12 A Output
- Isolated
- Over Temperature Protection
- Fixed Frequency (260 kHz)
- SCP/OCP
- High Efficiency
- Low Cost
- High Power Density
- Remote On/Off
- Input Under-Voltage Lockout
- Basic Isolation
- Input Over-Voltage Lockout
- Output Over-Voltage Shutdown
- Positive/Negative Remote Sense
- Output Voltage Trim
- Class II, Category 2, Isolated DC/DC Converter (refer to IPC-9592A)
- UL60950-1 Recognized (UL/cUL)

Applications

- Networking
- Computers and Peripherals
- Telecommunication



bel POWER
SOLUTIONS &
PROTECTION

a bel group

belfuse.com/power-solutions

1. MODEL SELECTION

OUTPUT VOLTAGE	INPUT VOLTAGE	MAX. OUTPUT CURRENT	MAX. OUTPUT POWER	TYPICAL EFFICIENCY	MODEL NUMBER ACTIVE LOW	MODEL NUMBER ACTIVE HIGH
12 VDC	18 - 75 VDC	12 A	144 W	93%	0RQB-C5U12L	0RQB-C5U120

NOTE: 1. Add "G" suffix at the end of the model number to indicate Tray Packaging.

PART NUMBER EXPLANATION

0	R	QB	-	C5	U	12	x	G
Mounting Type	RoHS Status	Series Name		Output Power	Input Range	Output Voltage	Active Logic	Package
0 - Through hole mount	RoHS	1/4 th Brick		144W	18 – 75 V	12 V	0-Active high L-Active Low	G-Tray package

2. ABSOLUTE MAXIMUM RATINGS

PARAMETER	DESCRIPTION	MIN	TYP	MAX	UNITS
Continuous Input Voltage		-0.3	-	80	V
Input Transient Voltage	100ms maximum	-	-	100	V
Remote On/Off		-0.3	-	18	V
I/O Isolation Voltage		-	-	1500	V
Ambient Temperature		-40	-	85	°C
Storage Temperature		-55	-	125	°C

NOTE: Ratings used beyond the maximum ratings may cause a reliability degradation of the converter or may permanently damage the device

3. INPUT SPECIFICATIONS

PARAMETER	DESCRIPTION	MIN	TYP	MAX	UNIT
Input Voltage	Operating	18	24/48	75	V
Input Current (full load)	V _{in} =18 V	-	9.2	-	A
	V _{in} =75 V	-	2.2	-	A
Input Current (no load)		-	100	130	mA
Remote Off Input Current		-	30	45	mA
Input Reflected Ripple Current (pk-pk)	With simulated source impedance of 10 μ H, 5 Hz to 20 MHz; Use a 1 μ F/100V ceramic capacitor and a 100 μ F/100V electrolytic capacitor with ESR=1 ohm max, at 200KHz@25°C.	-	40	60	mA
Input Reflected Ripple Current (rms)		-	10	15	mA
I ² t Inrush Current Transient		-	-	0.5	A ² s
Turn-on Voltage Threshold		16.5	17.0	17.5	V
Turn-off Voltage Threshold		15.5	16.0	16.5	V
Input Over Voltage Lockout		76	78	80	V

CAUTION: This converter is not internally fused. An input line fuse must be used in application.

Recommend a fast-acting fuse with maximum rating of 15A on system board. Refer to the fuse manufacture's datasheet for further information.

NOTE: 1. This converter has internal C-L-C (0.47 μ F-0.47 μ H-8.8 μ F) filter.
2. All specifications are typical at 25 °C unless otherwise stated.

4. OUTPUT SPECIFICATIONS

PARAMETER	DESCRIPTION	MIN	TYP	MAX	UNIT	
Output Voltage Set Point	Vin=48 V, Io=50% load	11.76	12.0	12.24	V	
Line Regulation		-	±12	±24	mV	
Load Regulation		-	±12	±24	mV	
Regulation Over Temperature (-40 °C – 85 °C)		-	±60	±100	mV	
Output Current Range		0	-	12	A	
Output Ripple and Noise (pk-pk)	0 - 20 MHz BW, with 1 µF ceramic load capacitor and a 10 µF tantalum capacitor at output	-	100	160	mV	
Output Ripple and Noise (rms)		-	30	50	mV	
Ripple and Noise (pk-pk) under worst case	Over all operating input voltage, load and ambient temperature condition.	-	-	180	mV	
Output DC Current Limit		15	-	20	A	
Short Circuit Surge Transient		-	3	5	A ² s	
Turn on Time	Enable form Vin Enable form ON/OFF	-	50	70	ms	
Rise Time		10	-	20	ms	
Overshoot at Turn on		-	0	3	%	
Output Capacitance		0	-	8000	µF	
TRANSIENT RESPONSE						
ΔV 25% ~ 50% of Max Load	Overshoot	di/dt=0.1A/µs, Vin=48VDC, Ta=25°C, with a 1µF ceramic capacitor and a 10µF Tantalum cap at output.	-	400	600	mV
	Settling Time		-	200	300	µs
ΔV 50% ~ 25% of Max Load	Overshoot	V _o =5 V	-	400	600	mV
	Settling Time		-	200	300	µs

NOTE: All specifications are typical at nominal input, full load at 25°C unless otherwise stated.

5. GENERAL SPECIFICATIONS

PARAMETER	DESCRIPTION	MIN	TYP	MAX	UNIT
Efficiency	Vin=48 V, full load	91	93	-	%
	Vin=24 V, full load	91	93	-	%
Switching Frequency		240	260	280	kHz
Output voltage trim range		80	-	120	%
FIT	Calculated Per Bell Core SR-332 (Vin=48V, Vo=12V, Io=9.6A, Ta = 25 °C, FIT=10 ⁹ /MTBF)		387		-
Over Temperature Protection		-	125	-	°C
Over Voltage Protection (Static)	This voltage is achieved by trimming up output slowly	-	14.5	-	V
ISOLATION CHARACTERISTICS					
Isolation Capacitance		-	1500	-	pF
Isolation Resistance		10M	-	-	Ohm
Input to Output		-	-	1500	VDC
Input to case		-	-	1500	VDC
Output to case		-	-	500	VDC
Weight		-	48	-	
Dimensions (L x W xH)			2.30 x 1.45 x 0.50 58.42 x 36.83 x 12.69		inch mm

NOTE: All specifications are typical at 25 °C unless otherwise stated.

6. EFFICIENCY DATA

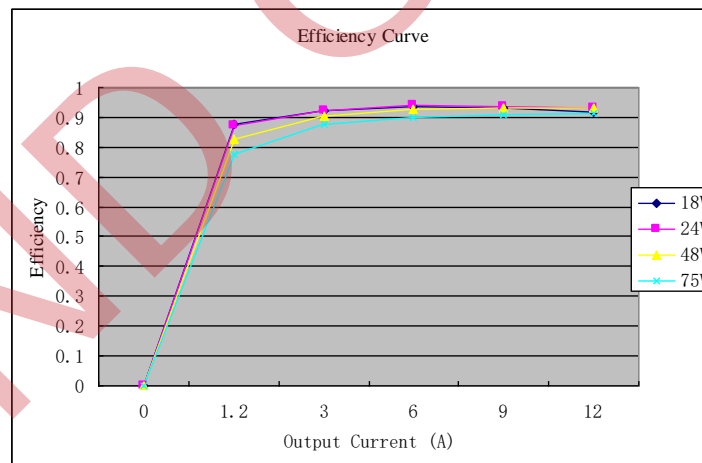

7. REMOVE ON/OFF

PARAMETER		DESCRIPTION	MIN	TYP	MAX	UNIT
REMOTE ON/OFF						
Signal Low (Unit On)	Active Low	0RQB-C5U12L.	-0.3	-	0.8	V
Signal High (Unit Off)		The remote on/off pin open, Unit off.	2.4	-	18	
Signal Low (Unit Off)	Active High	0RQB-C5U120.	-0.3	-	0.8	V
Signal High (Unit On)		The remote on/off pin open, Unit on.	2.4	-	18	
Current Sink		-	0	-	1	mA

Recommended remote on/off circuit for active low

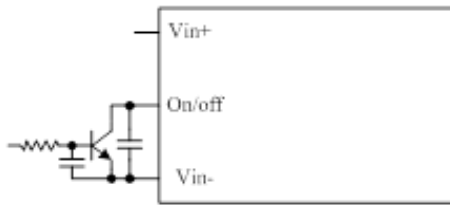

Control with open collector/drain circuit

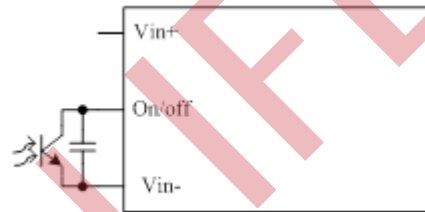

Control with photocoupler circuit

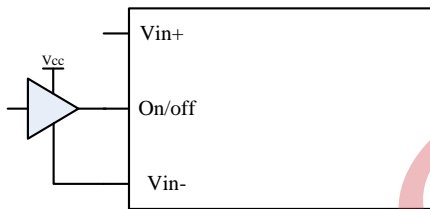

Control with logic circuit

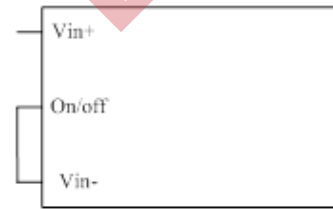

Permanently on

Recommended remote on/off circuit for active high

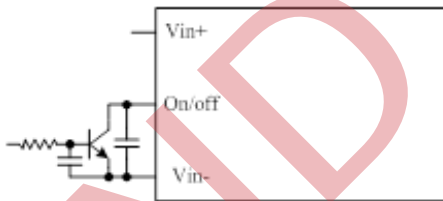

Control with open collector/drain circuit

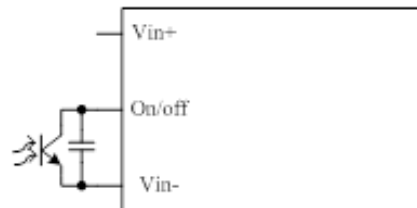

Control with photocoupler circuit

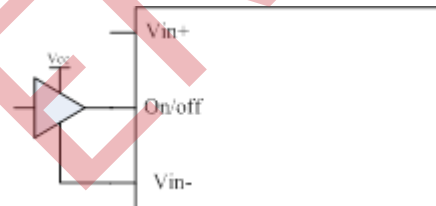

Control with logic circuit



Permanently on

8. INPUT UNDER-VOLTAGE LOCKOUT

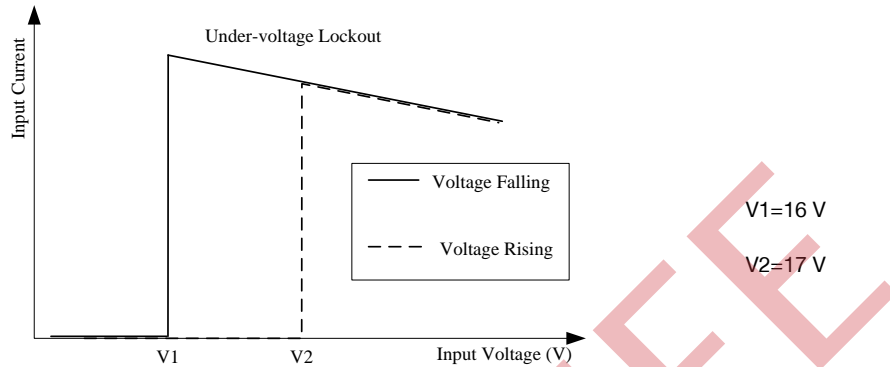

9. RIPPLE AND NOISE WAVEFORM

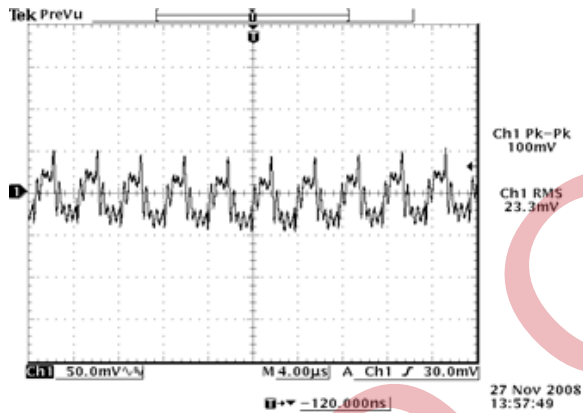

Figure 1. 24VDC input, 12VDC/12A output

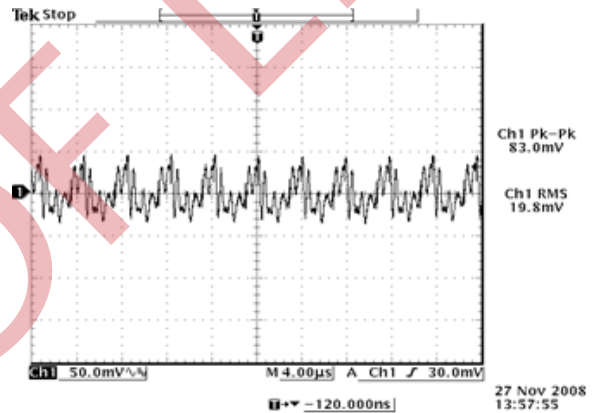

Figure 2. 48VDC input, 12VDC/12A output

NOTE: Ripple and noise at full load, with a 1µF ceramic cap and a 10 µF Tantalum cap at output, Ta=25 °C.

10. THERMAL DERATING CURVES

Maximum junction temperature of semiconductors derated to 120 °C.

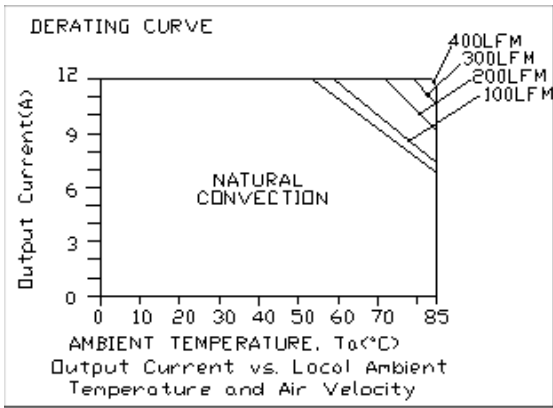

Figure 3. $V_{in}=24V$
Derating curve under normal input

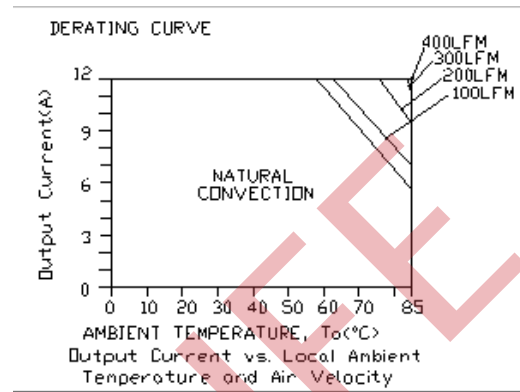
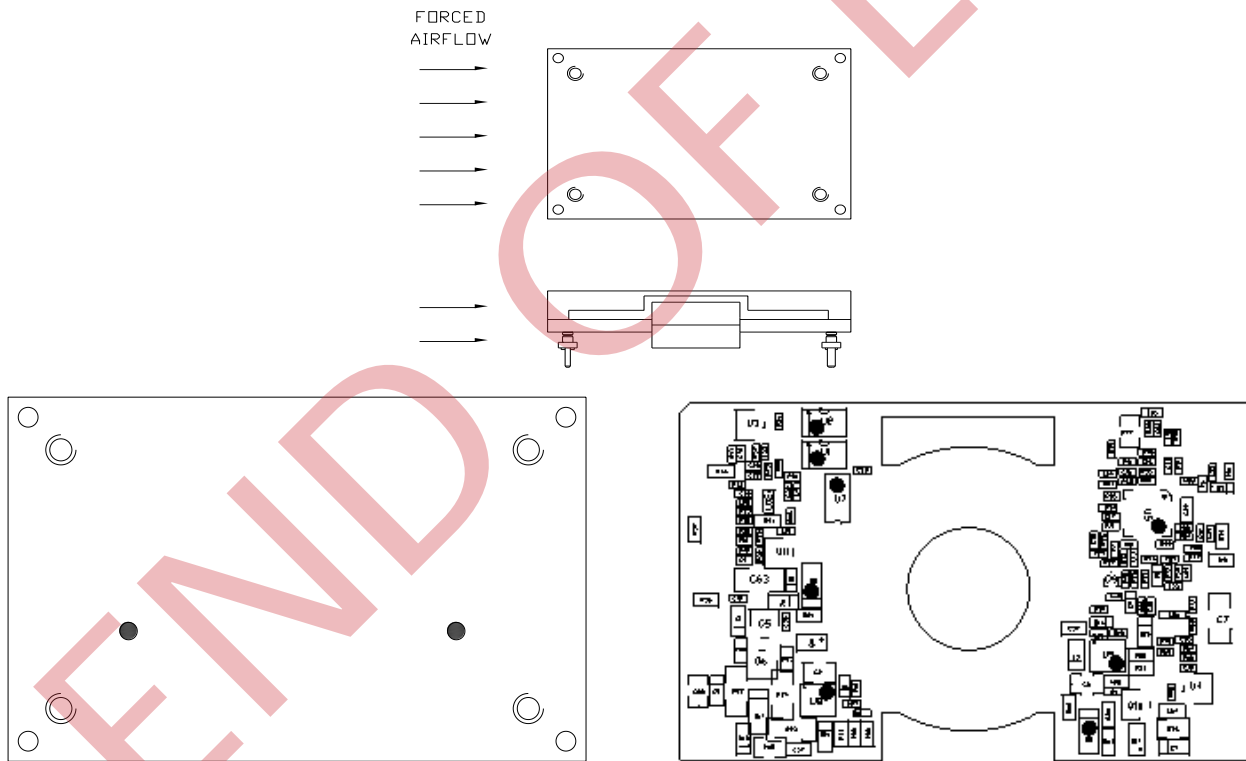

Figure 4. $V_{in}=48V$
Derating curve under normal input



Temperature reference points on top side

Temperature reference points on bottom side

11. STARTUP & SHUTDOWN

RISE TIME

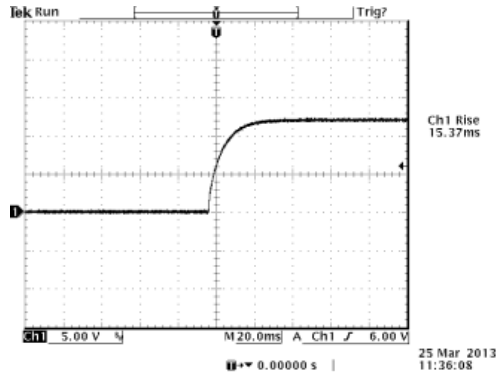

Figure 5. $V_{out} = 12V/12A$ at $V_{in} = 48V @ T_a = 25^\circ C$

STARTUP TIME

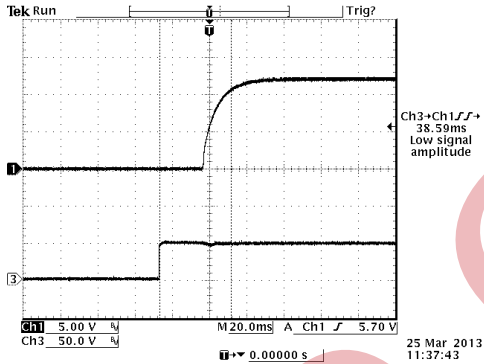

Figure 6. Startup from Vin
Ch1: Vo
Ch3: Vin
Test Condition: 48Vin, 12A Load

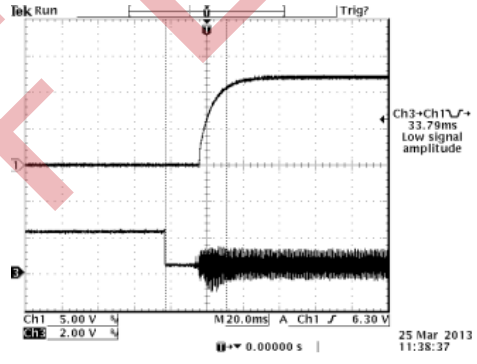

Figure 7. Startup from on/off
Ch1: Vo
Ch3: on/off
Test Condition: 48Vin, 12A Load

SHUTDOWN

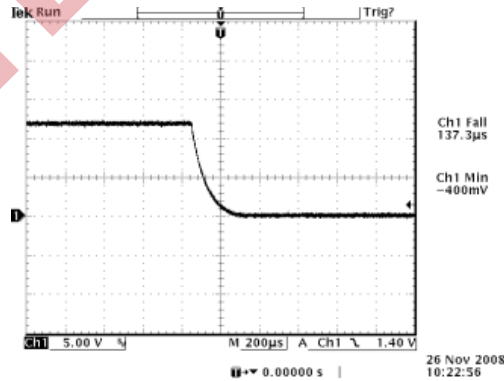

Figure 8. Test Condition: 48 Vin, 12 Load

12. TRANSIENT RESPONSE WAVEFORMS

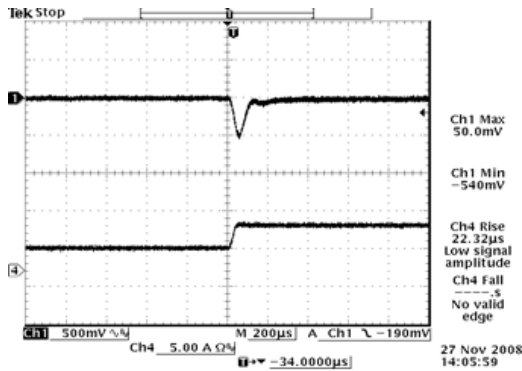

Figure 9. 25%-50% Load Transients at $V_{in}=24V$, $V_{out}=12V$

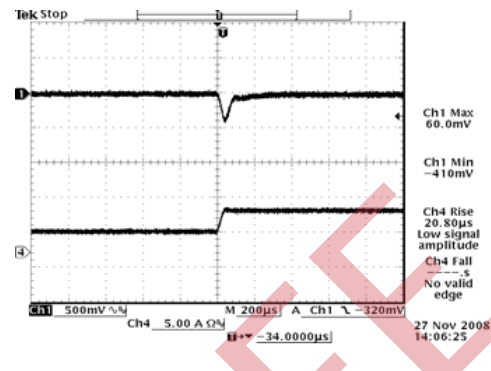

Figure 10. 50%-25% Load Transients at $V_{in}=48V$, $V_{out}=12V$

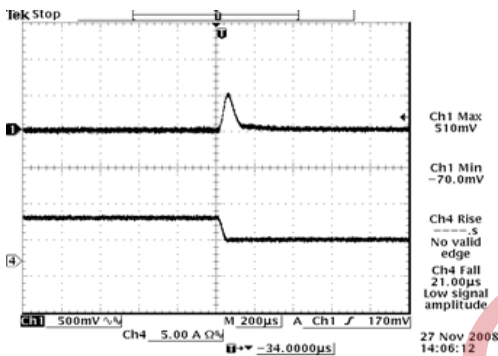

Figure 11. 50%-25% Load Transients at $V_{in}=24V$, $V_{out}=12V$

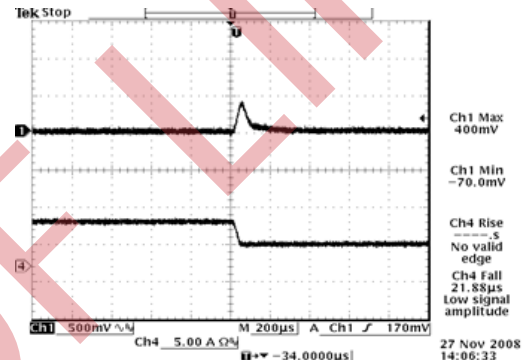
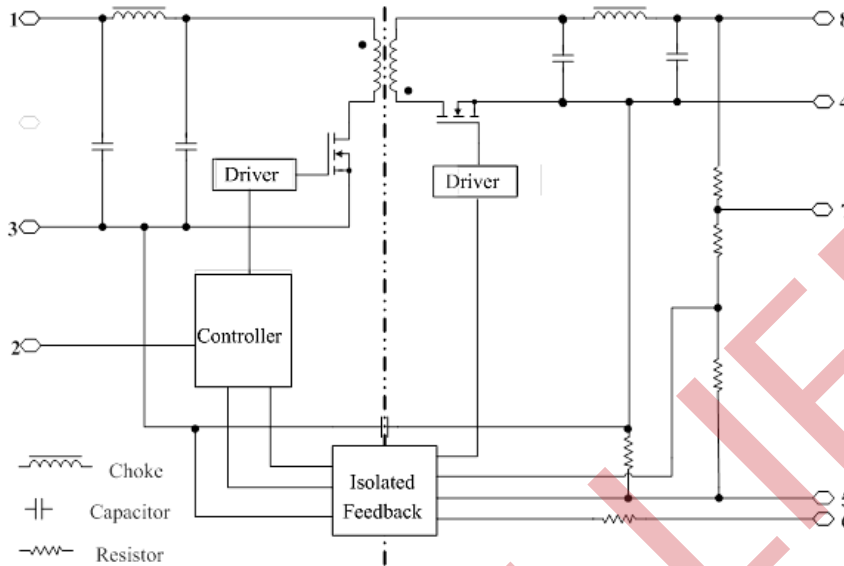

Figure 12. 50%-25% Load Transients at $V_{in}=48V$, $V_{out}=12V$

NOTE: Transient Response at $di/dt=0.1A/\mu s$, with a $1\mu F$ ceramic cap and a $10\mu F$ aluminum cap at the output, $T_a=25^\circ C$.

13. FUNDAMENTAL CIRCUIT DIAGRAM



14. OUTPUT TRIM EQUATIONS

Equations for calculating the trim resistor are shown below. The Trim Down resistor should be connected between the Trim pin and Sense (-) pin. The Trim Up resistor should be connected between the Trim pin and the Sense (+). Only one of the resistors should be used for any given application.

Minimum trim down voltage is 10.8V

Maximum trim up voltage is 13.2V.

The total voltage increased by trim and remote sense should not exceed 10% of the nominal output voltage.

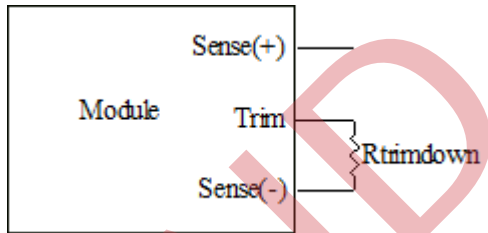

$$R_{trimdown} = \frac{511}{|\Delta|} - 10.22 [k\Omega]$$

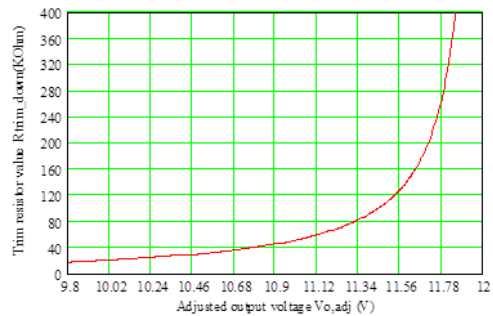
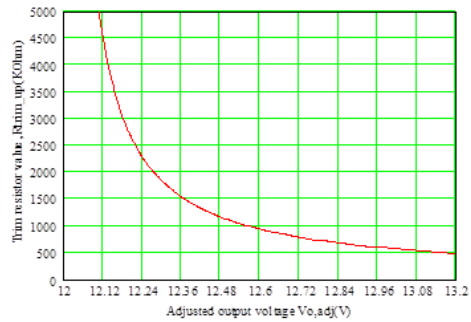
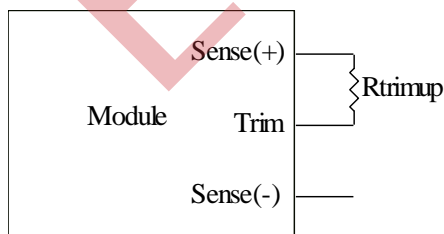

$$R_{trimup} = \frac{(100 + \delta) \cdot V_o \cdot 5.11 - 626}{1.225 \cdot \delta} - 10.22 [k\Omega]$$

NOTES:

V_{o_req} = Desired(trimmed) output voltage[V]

Output voltage $V_o = 12.000$ V

$$\delta = \frac{(V_{o_req} - V_o)}{V_o} \times 100 [\%]$$

15. REMOTE SENSE

This module has remote sense compensation feature. It can minimize the effects of resistance between module's output and load in system layout and facilitates accurate voltage regulation at load terminals or other selected point.

1. The remote sense lines carries very little current and hence do not require a large cross-sectional area.
2. This module compensates for a maximum drop of 10% of the nominal output voltage.
3. If the unit is already trimmed up, the available remote sense compensation range should be correspondingly reduced. The total voltage increased by trim and remote sense should not exceed 10% of the nominal output voltage.
4. When using remote sense compensation, all the resistance, parasitic inductance and capacitance of the system are incorporated within the feedback loop of this module. The can make an effect on the module's compensation, affecting the stability and dynamic response. A 0.1µF ceramic capacitor can be connected at the point of load to de-couple noise on the sense wires.
5. Recommend the connection of remote sense compensation as below figure. There are a resistor $RS+$ (100 ohm) from $Vo+$ to Sense+ and a resistor $RS-$ (51 ohm) from $Vo-$ to Sense- inside of this module.

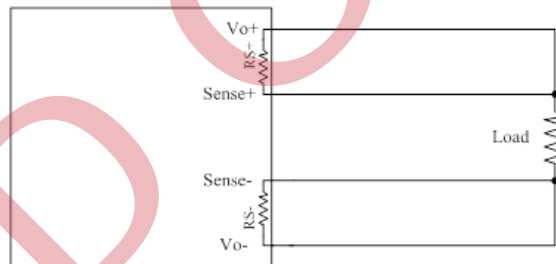

6. If not using remote sense compensation, please connect sense directly to output at module's pin, that is, connect sense+ to $Vo+$ and sense- to $Vo-$ at module's pin, the shorter the better. see below figure.

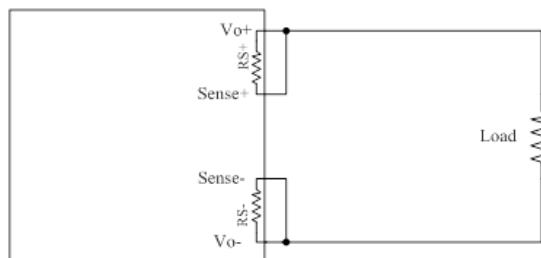

16. OVER CURRENT PROTECTION

To provide protection in a fault output overload condition, the module is equipped with internal current-limiting circuitry and can endure current limiting for a few milliseconds. If the over current condition persists beyond a few milliseconds, the module will shut down into hiccup mode and restart once every 400ms. The module operates normally when the output current goes into specified range. The typical average output current is 0.5A during hiccup.

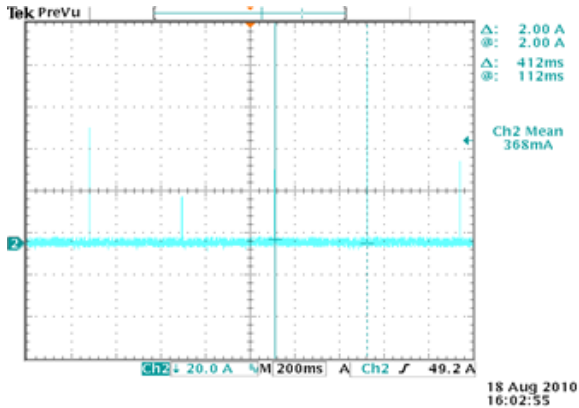

Figure 13. $V_{in}=48V$

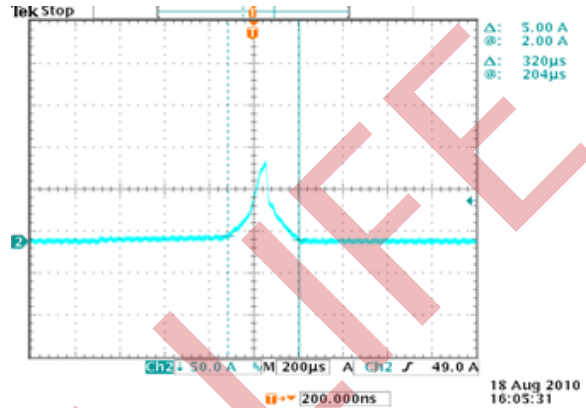
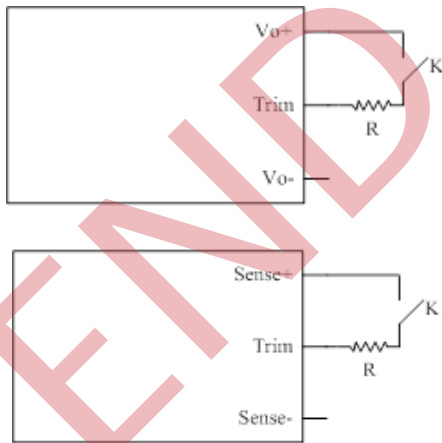

Figure 14. Expansion of on time portion

17. OVER VOLTAGE PROTECTION

The output overvoltage protection consists of circuitry that monitors the voltage on the output terminals. If the voltage on the output terminals exceeds the over voltage protection threshold, the module will shutdown into hiccup mode and restart once every 560mS. The module operates normally when the fault is cleared.

TEST SETUP:



R=80K

WAVEFORM:

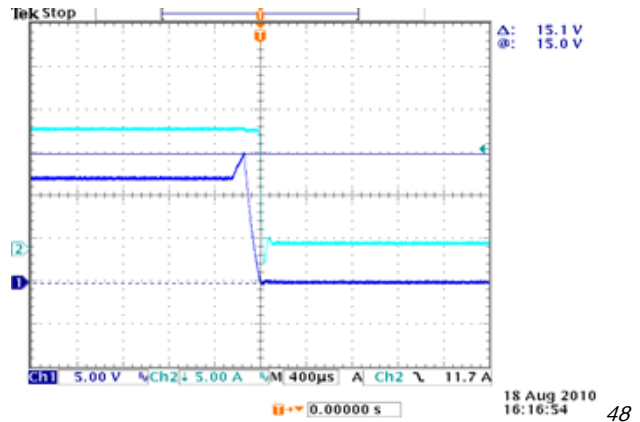

V_{in} , 12A Load

CH1: Output voltage waveform
CH2: Output Current waveform

18. OVER TEMPERATURE PROTECTION

The OTP is achieved by thermistor RT and the threshold is set at 120 °C in non-latch mode; the hottest component Q12 reaches 130 °C with 100LFM air flow correspondingly. It will restart automatically when the temperature falls down to 100 °C. The protecting point will be varied a little under different conditions (air flow, ambient temperature, input voltage, load...).

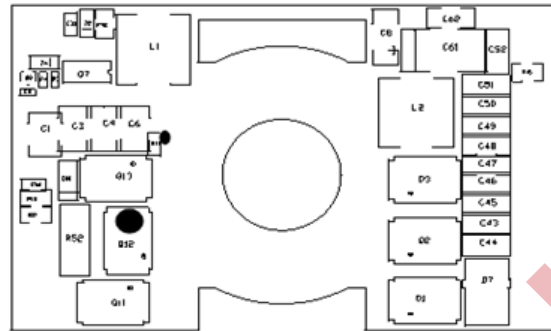

TOP VIEW

19. SAFETY & EMC

SAFETY:

- 1. Material flammability UL94V-0
- 2. UL Certification UL60950-1

EMC:

- 1. Surge: IEC61000-4-5
- 2. DC-DIP: IEC61000-4-29
- 3. Conductive EMI: EN55022 class A

Compliance to EN55022 class A (both q.peak and average) with the following inductive and capacitive filter

SETUP:

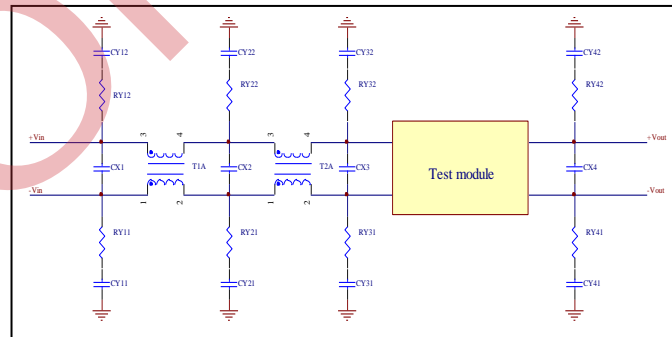

ITEM	DESIGNATOR	PARAMETER	VENDOR	VENDOR P/N
1	CX1,CX2	2.2µF/100V,ceramic	Murata	GRF32ER72A225KA11L
2	C3X	100µF/100V, AL cap	Nichicon	UVZ2A101MPD
3	RY21,RY22	0R,0805	SEI	
4	CY21,CY22	6800pF/2000V,ceramic	Johanson	202R29W682KV4E
5	RY31,RY32	51R,0805	SEI	
6	CY31,CY32	1500pF/2000V,ceramic	Johanson	302R29W152KV4E
7	RY41,RY42	0R,0805	SEI	
8	CY41,CY42	1500pF/2000V,ceramic	Johanson	302R29W152KV4E
9	T1A	1.0mH, common mode		
10	T2A	2.2mH,common mode		

POSITIVE

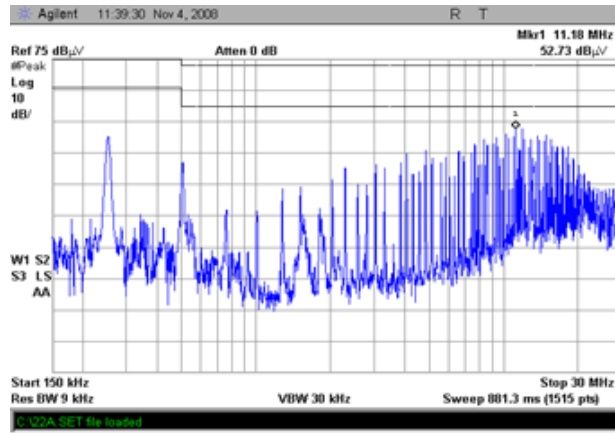

NEGATIVE

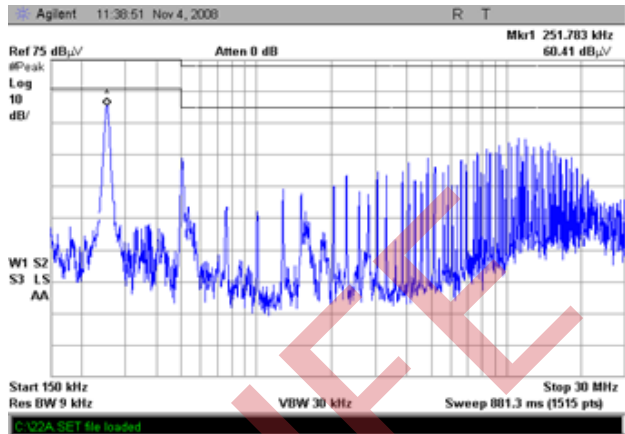

20. LAYOUT

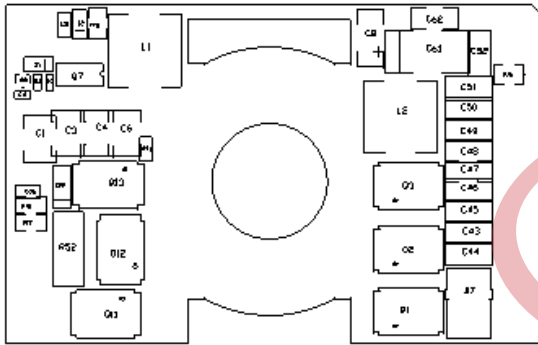

TOP VIEW

Figure 15. Layout of components on top side

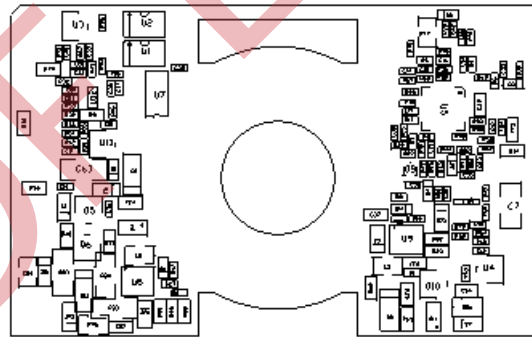

BOTTOM VIEW

Figure 16. Layout of components on bottom side

21. MECHANICAL OUTLINE

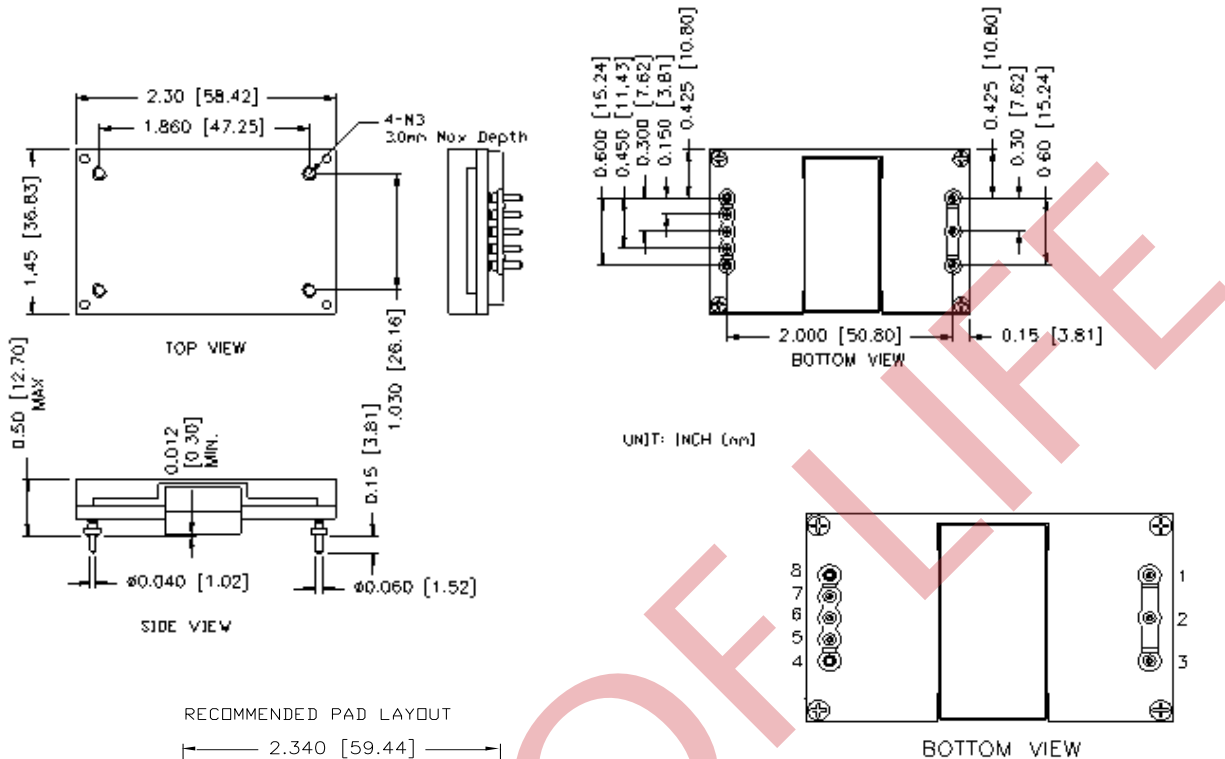

UNIT: INCH (mm)

PIN CONNECTIONS

PIN	FUNCTION	PIN SIZE
1	Vin(+)	0.040"
2	On/Off	0.040"
3	Vin(-)	0.040"
4	Vo(-)	0.060"
5	Sense(-)	0.040"
6	TRIM	0.040"
7	Sense(+)	0.040"
8	Vo(+)	0.060"

NOTE: This module is recommended and compatible with Pb-Free Wave Soldering and must be soldered using a peak solder temperature of no more than 260 °C for less than 5 seconds.

NOTE:

- 1) All Pins: Material - Copper Alloy;
Finish - 3 micro inches minimum Gold over 50 micro inches minimum Nickel plate.
- 2) Undimensioned components are shown for visual reference only.
- 3) All dimensions in inches (mm); Tolerances: x.xx +/-0.02 in. (x.x +/-0.5mm) x.xxx +/-0.010 in. (x.xx +/-0.25mm).



Asia-Pacific
+86 755 298 85888

Europe, Middle East
+353 61 225 977

North America
+1 408 785 5200

22. REVISION HISTORY

DATE	REVISION	CHANGES DETAIL	APPROVAL
2008-06-24	PA	First release	JZ Wang
2009-03-10	B	Updated MD, TR, NR and Efficiency, add TD	JZ Wang
2009-12-29	C	Update outline and MD	JZ Wang
2010-08-19	D	Add Shutup & Shutdown, Remote on/off, Layout, Remote sense, OCP, OVP, OTP, UVLO, Safety & EMC and Fundamental circuit diagram.	JZ Wang
2011-12-12	E	Updated mechanical outline.	JZ Wang
2013-03-25	F	Update rise time and output capacitance.	JZ Wang

END OF LIFE

For more information on these products consult: tech.support@psbel.com

NUCLEAR AND MEDICAL APPLICATIONS - Products are not designed or intended for use as critical components in life support systems, equipment used in hazardous environments, or nuclear control systems.

TECHNICAL REVISIONS - The appearance of products, including safety agency certifications pictured on labels, may change depending on the date manufactured. Specifications are subject to change without notice.